

# Fluid condition sensor

for high-performance inline fluid monitoring



## Applications

- Condition monitoring of various liquids
- Inline oil analysis
- Factory automation
- Retrofitting
- Automotive



## Features

- Stainless steel housing
- IP 67 ingress protection
- Modbus RTU interface
- Industry standard M12 connector
- 2x 4-20 mA outputs
- Made in Austria



## Measured parameters

- Viscosity 1-650 mm<sup>2</sup>/s
- Density 0.5-1.5 g/cm<sup>3</sup>
- Temperature -40 to 125 °C

Update rate of all parameters 1/s



## Benefits

- Easy to integrate screw-mount design
- Plug-and-play operation
- 24/7 inline monitoring
- Excellent long-term stability
- Extended measurement range
- Unrivalled measurement accuracy
- High time resolution
- Operation in pressurized environments

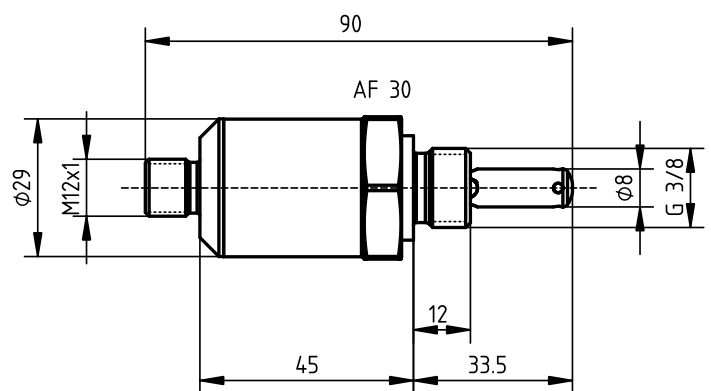

The Micro Resonant ICMS continuously monitors fluid condition based on accurate sensing of viscosity, density, and temperature. It features an extended viscosity range, increased accuracy, and high sampling rates. The ground-breaking performance is achieved by transforming the patented Micro Resonant sensor evaluation technology to the smallest possible size while maintaining a competitive price. The ICMS is easy to integrate providing standard industrial interfaces.

